

TIGERCUB CD — Dimensions & Weights

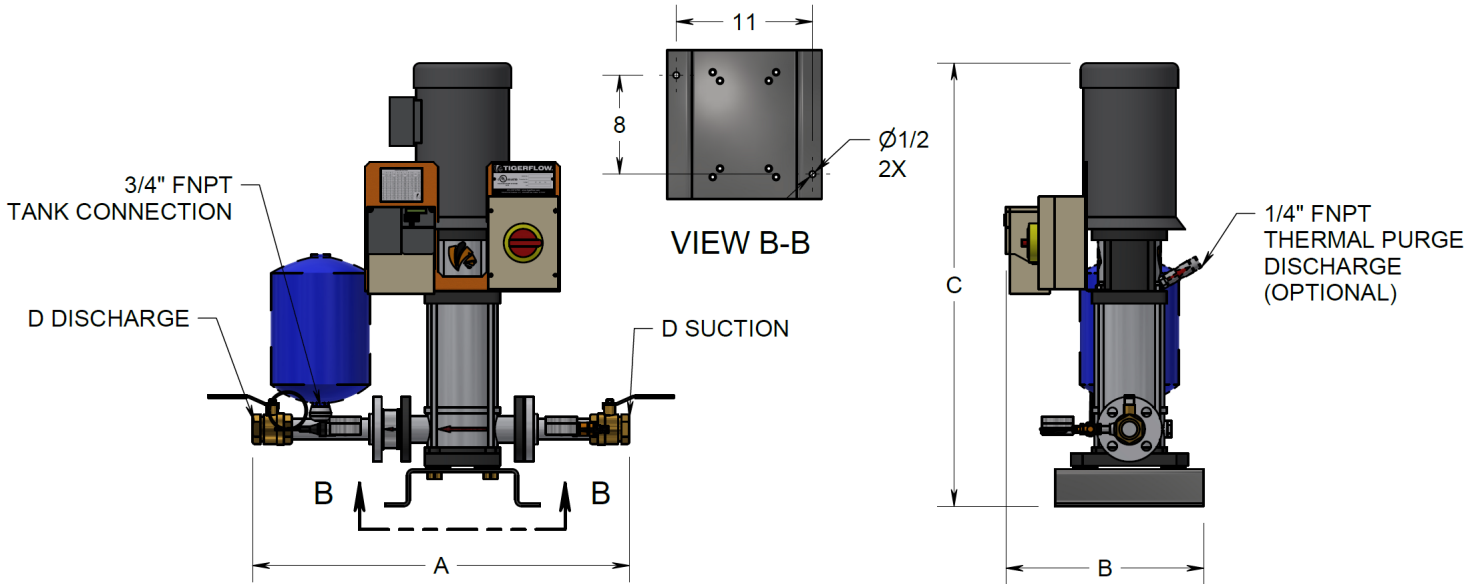

TIGERFLOW



PN			MODEL	HP	A (in)	B (in)	C (in)	D	WEIGHT (lb)	PEI _{CL}
208V/230V/1Φ	208V/230V/3Φ	460V/3Φ								
	3300005180	3300005191	3300005192	CD3-5	1	30.5	16	1 1/4	128	0.76
	3300005193	3300005194	3300005195	CD3-7	1.5				133	0.76
	3300005196	3300005197	3300005198	CD3-10	2				146	0.72
	3300005267	3300005274	3300005284	CD3-12	3				155	0.70
	3300005199	3300005200	3300005201	CD3-14	3				160	0.72
	3300005202	3300005203	3300005204	CD3-16	3				162	0.70
	3300005268	3300005275	3300005285	CD3-16	5				187	0.70
	3300005205	3300005206	3300005207	CD3-18	5				189	0.71
	3300005208	3300005209	3300005210	CD5-3	1				130	0.89
	3300005211	3300005212	3300005213	CD5-4	1.5				131	0.83
	3300005214	3300005215	3300005216	CD5-6	2				144	0.84
	3300005217	3300005218	3300005219	CD5-7	3				153	0.80
	3300005269	3300005276	3300005286	CD5-9	3				155	0.82
	3300005220	3300005221	3300005222	CD5-10	3				160	0.80
	3300005270	3300005277	3300005287	CD5-12	5				187	0.81
	3300005223	3300005224	3300005225	CD5-13	5				189	0.80
	3300005271	3300005278	3300005288	CD5-15	5				191	0.79
	3300005226	3300005227	3300005228	CD5-16	5				196	0.79
		3300005279	3300005289	CD5-18	7.5				217	0.81
		3300005229	3300005230	CD5-20	7.5				219	0.80
	3300005231	3300005232	3300005233	CD10-2	2	34.25	17	2	159	0.88
	3300005272	3300005280	3300005290	CD10-3	3				171	0.89
	3300005234	3300005235	3300005236	CD10-4	3				173	0.90
	3300005237	3300005238	3300005239	CD10-4	5				198	0.90
	3300005273	3300005281	3300005291	CD10-5	5				198	0.89
	3300005240	3300005241	3300005242	CD10-6	5				204	0.89
		3300005282	3300005292	CD10-7	7.5				225	0.87
		3300005283	3300005293	CD10-8	7.5				276	0.88
		3300005243	3300005244	CD10-9	7.5				236	0.87
	3300005245	3300005246	3300005247	CD15-2	5				193	0.94
	3300005248	3300005249	3300005250	CD15-3	5				198	0.90
		3300005251	3300005252	CD15-3	7.5				219	0.90
		3300005253	3300005254	CD15-4	7.5				219	0.91
	3300005255	3300005256	3300005257	CD20-2	5				193	0.97
		3300005258	3300005259	CD20-3	7.5				219	0.95

PN: 3200018898 VALVE, THERMAL PURGE, 1/4"

Helps to prevent damage to the pump in low flow conditions.
The valve begins to open at 125°F and is fully open at 135°F.

MWP	400 PSI
OPENING TEMPERATURE	125°F
FULL OPEN TEMPERATURE	135°F



PN: 3200013721 EXPANSION TANK, 2 gallon

Minimizes system cycling during leak load conditions. Tanks
Tank is constructed with an NSF-61 certified antimicrobial liner.

MWP	150 PSI
MAXIMUM TEMPERATURE	200°F
FACTORY PRECHARGE	38 PSIG (2.6 Bar)



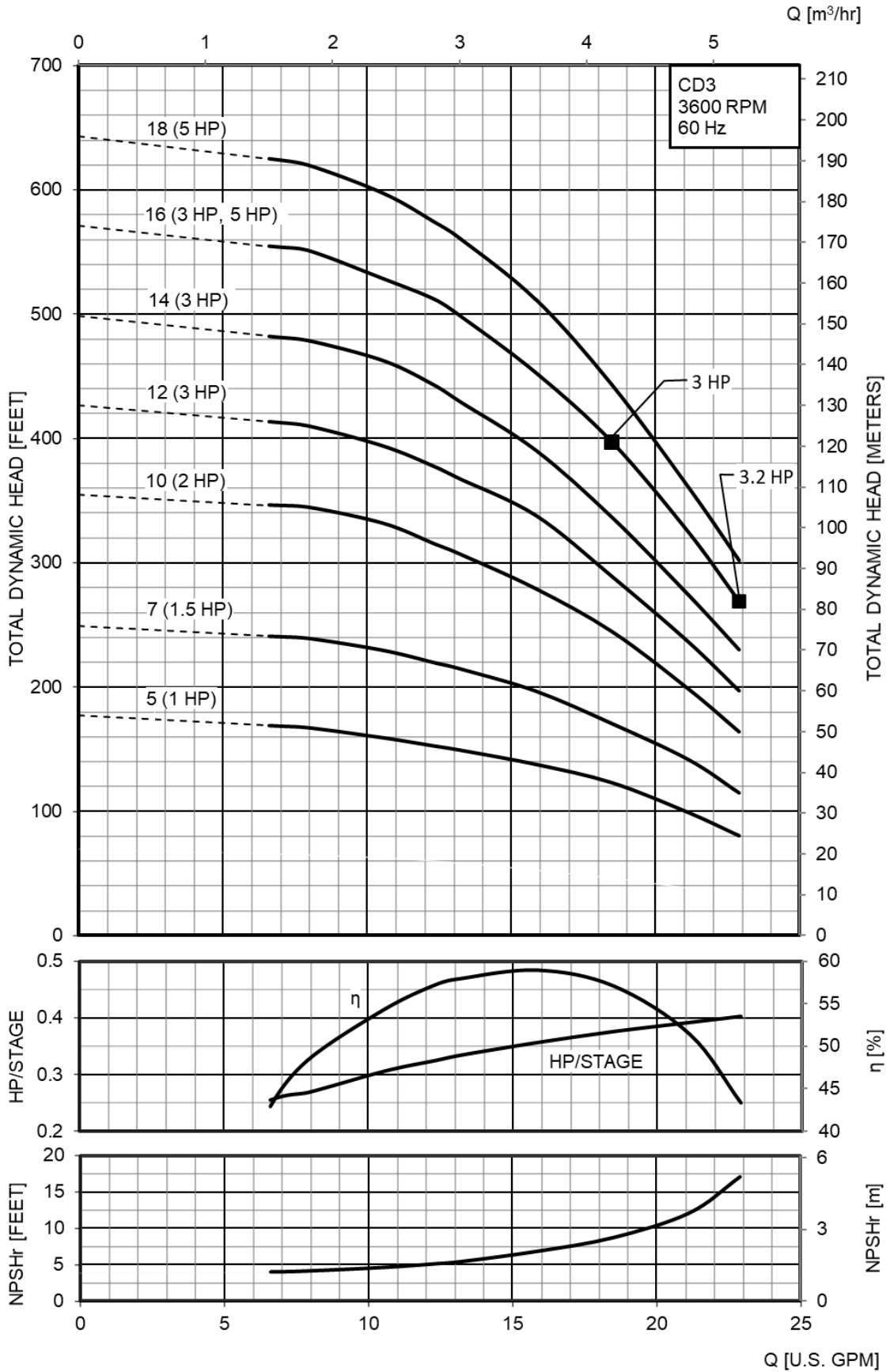

TIGERCUB CD — Performance Curves



TIGERFLOW®

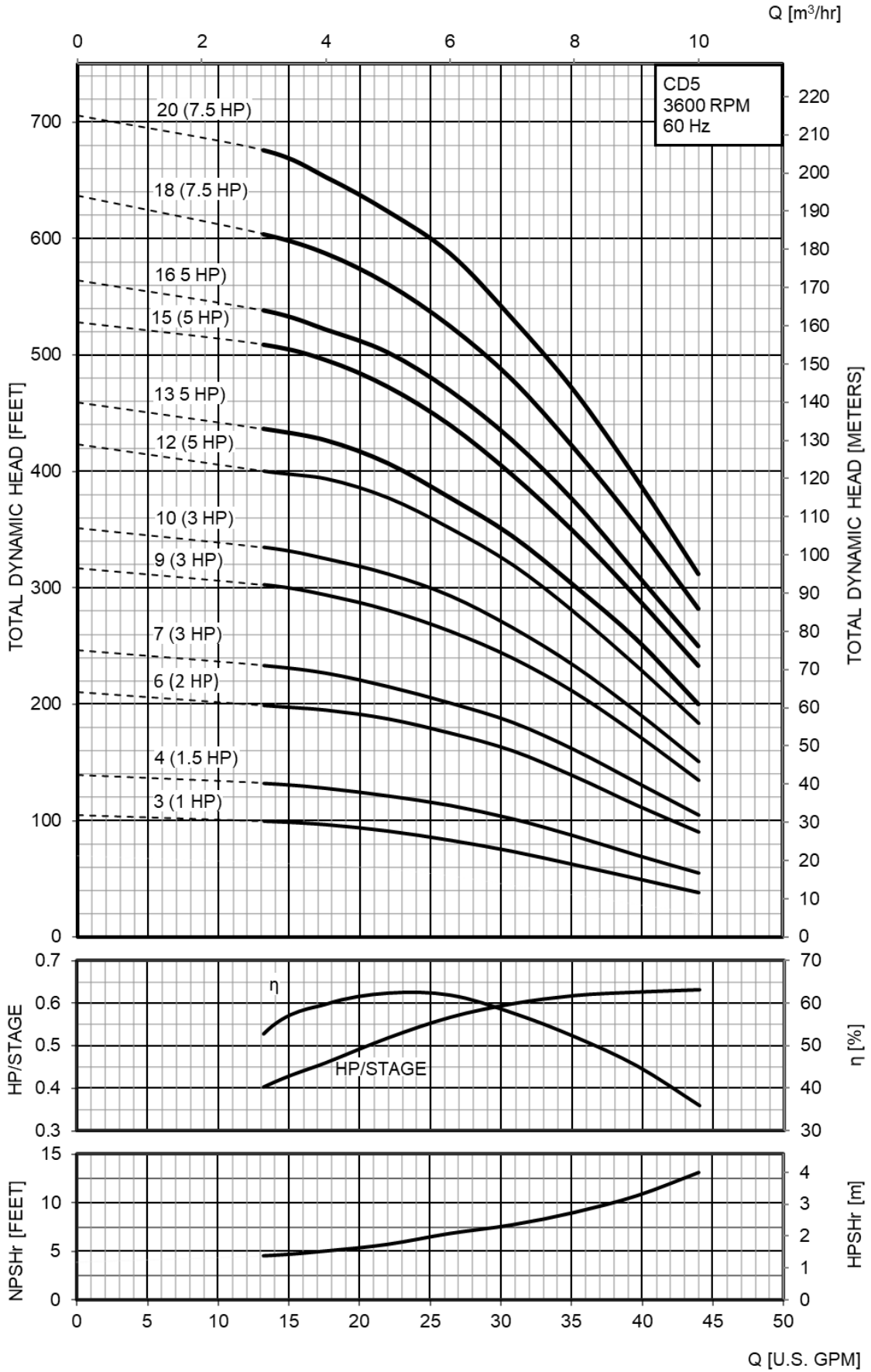

TIGERCUB CD — Performance Curves



TIGERFLOW®

