



HVAC

HVAC PUMPING SYSTEMS



TIGERFLOW®

Covers a wide array of pump units including primary, secondary for heating and cooling water systems and cooling tower applications

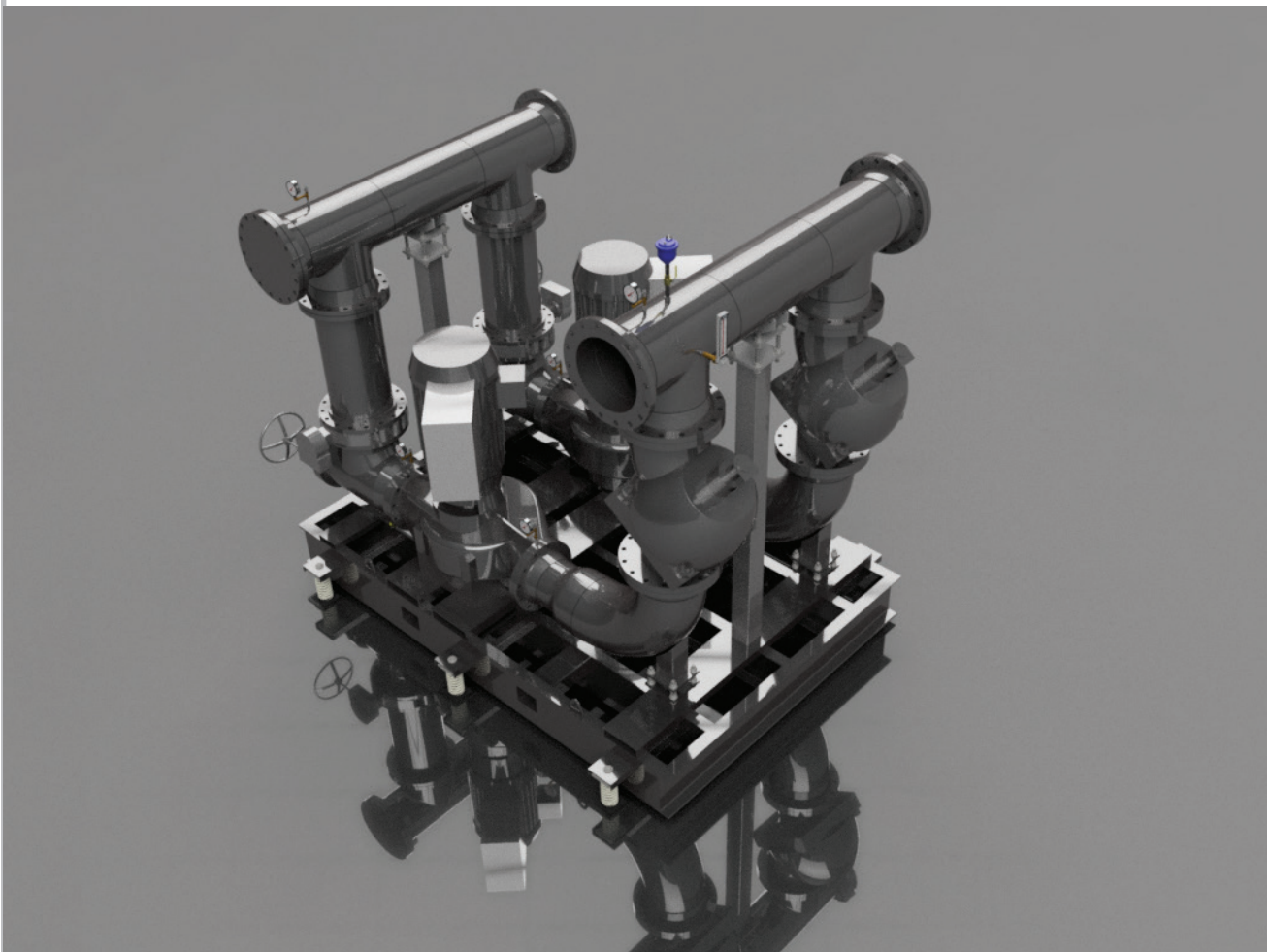

To place an order, please contact 214-337-8780 or hvac@tigerflow.com



HVAC

HVAC PUMPING SYSTEMS



TIGERFLOW[®]

BENEFITS

- Single source responsibility
- ASME section IX certified pipe welders
- AWS D1.1 certified structural welders
- UL/C-UL listed packaged pumping systems (QCZJ)
- UL 508A certified - standard for industrial control panels
- Touchscreen controller interface
- Prefabricated and factory tested
- Ability to provide customize software & control strategies
- Prefabricated and factory tested
- ASME code bladder tanks
- Custom design to meet specialized customer and job location requirements
- Dedicated project manager

STANDARD FEATURES

- PLC and HMI based control technology
- All piping designed in accordance with ASME B.31 piping codes
- All electrical installed in accordance with NEC and OSHA
- Suction diffusers, multi-purpose valves, air separators, chemical feed systems, isolation valves, control valves and controls

OPTIONS

- Wire-to-Water efficiency calculations
- Chemical feed systems
- Environmental enclosures with state certification

- Water make-up lines
- Modular design for reduced entryways

APPLICATIONS

- Schools
- Hospitals
- Commercial Buildings
- Apartment Buildings
- Stadiums
- Pharmaceutical Factories

CERTIFICATIONS

