



TIGERFLOW®

Product Guide



CD Vertical Multistage Pump

60Hz

Contents

Applications.....	4
Specifications	4
Pump	4
Motor	4
NPSHr	5
Model Key	6
Wet-end only CD3-CD20	6
Wet-end only CD32-CD85	6
Wet-end / Motor combination CD3-CD20.....	7
Wet-end / Motor combination CD32-85	8
CD Coverage & Curves	9
Dimensions and Weights CD3	10
Performance Curves CD3	11
Dimensions and Weights CD5	12
Performance Curves CD5	13
Dimensions and Weights CD10	14
Performance Curves CD10	15
Dimensions and Weights CD15	16
Performance Curves CD15	17
Dimensions and Weights CD20	18
Performance Curves CD20	19
Dimensions and Weights CD32	20
Performance Curves CD32	21
Dimensions and Weights CD42	22
Performance Curves CD42	23
Dimensions and Weights CD65	24
Performance Curves CD65	25
Dimensions and Weights CD85	26
Performance Curves CD85	27
Notes.....	28



Applications

- Pressure boosting for potable water systems
- Handling of solid free water in industrial and municipal facilities
- Fire system jockey pumps
- Boiler feed systems
- HVAC circulation systems
- Irrigation systems

Specifications

Pump

- 304/316 impellers & body
- Cast Iron/316 pump head & base
- Cartridge mechanical seal
- Flow: up to 570 U.S. GPM (130 m³/hr)
- Head: up to 805 feet (246 m)
- Liquid Temperature: 5°F to 248°F (-15°C +120°C)
- Minimum Efficiency Index (MEI) up to 0.7
- Maximum Working Pressure 362 psi (25 bar)

Motor

- NEMA TC frame, TEFC motors
- 2-pole
- The service factor shown on the motor nameplate indicates the amount of continuous overload the motor can be subjected to, under nameplate conditions, without damaging the motor. When the voltage and frequency are at the same values as shown on the motor nameplate, the motor may be overloaded up to the horsepower indicated by multiplying the rated horsepower by the service factor. When operated at service factor load, the motor may have an efficiency, power factor, and speed slightly different from those shown on the nameplate.

Service factor can also be used to determine if a motor can be operated continuously at altitudes higher than 3300 feet satisfactorily. At altitudes greater than 3300 feet, the lower density of air reduces the motor's cooling ability thereby causing the temperature of the motor to be higher. This higher temperature is compensated for by reducing the effective service factor to 1.0 on motors nameplated with a 1.15 service factor or greater. If the motor is operated outdoors at higher altitudes, it's sometimes possible to use full horsepower and full service factor since ambient temperatures are usually lower at those altitudes.

NPSHr

Net Positive Suction Head Required is the minimum suction pressure (in absolute pressure) required at the pump suction to avoid cavitation within the pump. Net Suction Positive Head Available (NPSHa) must be greater than than NPSHr. NPSHa is defined as follows:

$$NPSHr = h_a - h_{vp} - h_f + h_{st}$$

h_a = Absolute pressure (in feet of liquid being pumped) on the surface of the liquid supply level (this will be barometric pressure if suction is from an open tank or sump).

h_{vp} = The head in feet corresponding to the vapor pressure of the liquid at the temperature being pumped.

h_f = All suction line losses (in feet) including entrance losses and friction losses through pipe, valves and fittings, etc.

h_{st} = static height (in feet) that the liquid supply level is **above** the pump centerline or impeller eye.

Atmospheric pressure vs elevation			
Elevation (ft)	psia	ft	Atm
0	14.7	34	1
328	14.5	33.5	1
500	14.4	33.3	1
656	14.3	33	1
1000	14.2	32.8	1
1312	14	32.3	1
1500	13.9	32.1	0.9
2000	13.7	31.6	0.9
2500	13.4	31	0.9
3000	13.2	30.5	0.9
3500	12.9	29.8	0.9
4000	12.7	29.3	0.9
4500	12.4	28.6	0.9
5000	12.2	28.2	0.8
5500	12	27.7	0.8
6000	11.8	27.3	0.8
6500	11.5	26.6	0.8
7000	11.3	26.1	0.8
7500	11.1	25.6	0.8
8000	10.9	25.2	0.7
8500	10.7	24.7	0.7

Water Vapor Pressure	
Temperature	Vapor Pressure
°F	(ft H2O)
50	0.4
55.4	0.5
66.2	0.7
71.6	0.9
75.2	1
80.6	1.2
86	1.4
89.6	1.6
95	1.9
100.4	2.2
105.8	2.6
109.4	2.9
114.8	3.4
120.2	3.9

Model Key

Wet-end only CD3-CD20

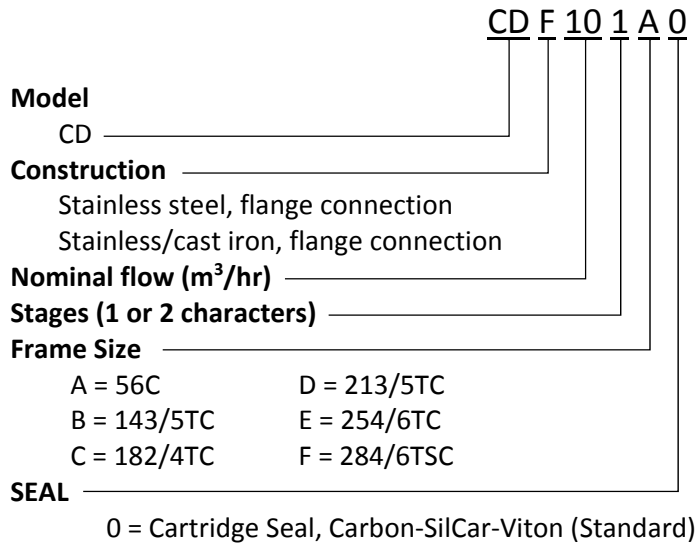

Wet-end only CD32-CD85

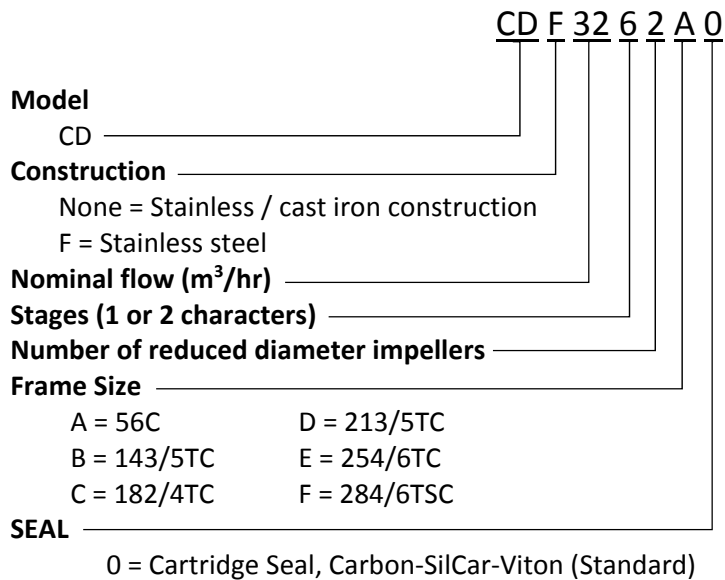

Wet-end / Motor combination CD3-CD20

CD F 10 1 A 0 D D 1 D

Model

CD

Construction

None = Stainless steel, flange connection

F = Stainless/cast iron, flange connection

Nominal flow (m³/hr)

Stages (1 or 2 characters)

Frame Size

A = 56C

D = 213/5TC

B = 143/5TC

E = 254/6TC

C = 182/4TC

F = 284/6TSC

SEAL

0 = Cartridge Seal, Carbon-SilCar-Viton (Standard)

HP

A=1/2	HP	G=5.0 HP	N=30 HP
B=3/4	HP	H=7.5 HP	P=40 HP
C=1.0	HP	J=10 HP	Q=50 HP
D=1.5	HP	K=15 HP	R=60 HP
E=2	HP	L=20 HP	T=75 HP
F=3	HP	M=25 HP	

VOLTAGE

A=115/230V	F=575V
B=208V	G=190V/380V
C=230V	H=190-380/415V
D=230/460V	J=415V
E=208-230/460V	

POLE/FREQUENCY/PHASE

- 1=2/60Hz/1φ
- 2=2/60Hz/3φ
- 3=2/50Hz/1φ
- 4=2/50Hz/3φ

MOTOR ENCLOSURE

A=ODP

B=TEFC

C=EXPLOSION PROOF

Wet-end / Motor combination CD32-85

CD F 32 4 2 A 0 D D 1 B

Model

CD

Construction

None = Stainless steel, flange connection

F = Stainless/cast iron, flange connection

Nominal flow (m³/hr)

Stages (1 or 2 characters)

Number of reduced diameter impellers

Frame Size

A = 56C

D = 213/5TC

B = 143/5TC

E = 254/6TC

C = 182/4TC

F = 284/6TSC

SEAL

0 = Cartridge Seal, Carbon-SilCar-Viton (Standard)

HP

A=1/2	HP	G=5.0 HP	N=30 HP
B=3/4	HP	H=7.5 HP	P=40 HP
C=1.0	HP	J=10 HP	Q=50 HP
D=1.5	HP	K=15 HP	R=60 HP
E=2	HP	L=20 HP	T=75 HP
F=3	HP	M=25 HP	

VOLTAGE

A=115/230V	F=575V
B=208V	G=190V/380V
C=230V	H=190-380/415V
D=230/460V	J=415V
E=208-230/460V	

POLE/FREQUENCY/PHASE

- 1=2/60Hz/1φ
- 2=2/60Hz/3φ
- 3=2/50Hz/1φ
- 4=2/50Hz/3φ

MOTOR ENCLOSURE

A=ODP

B=TEFC

C=EXPLOSION PROOF

CD Coverage & Curves

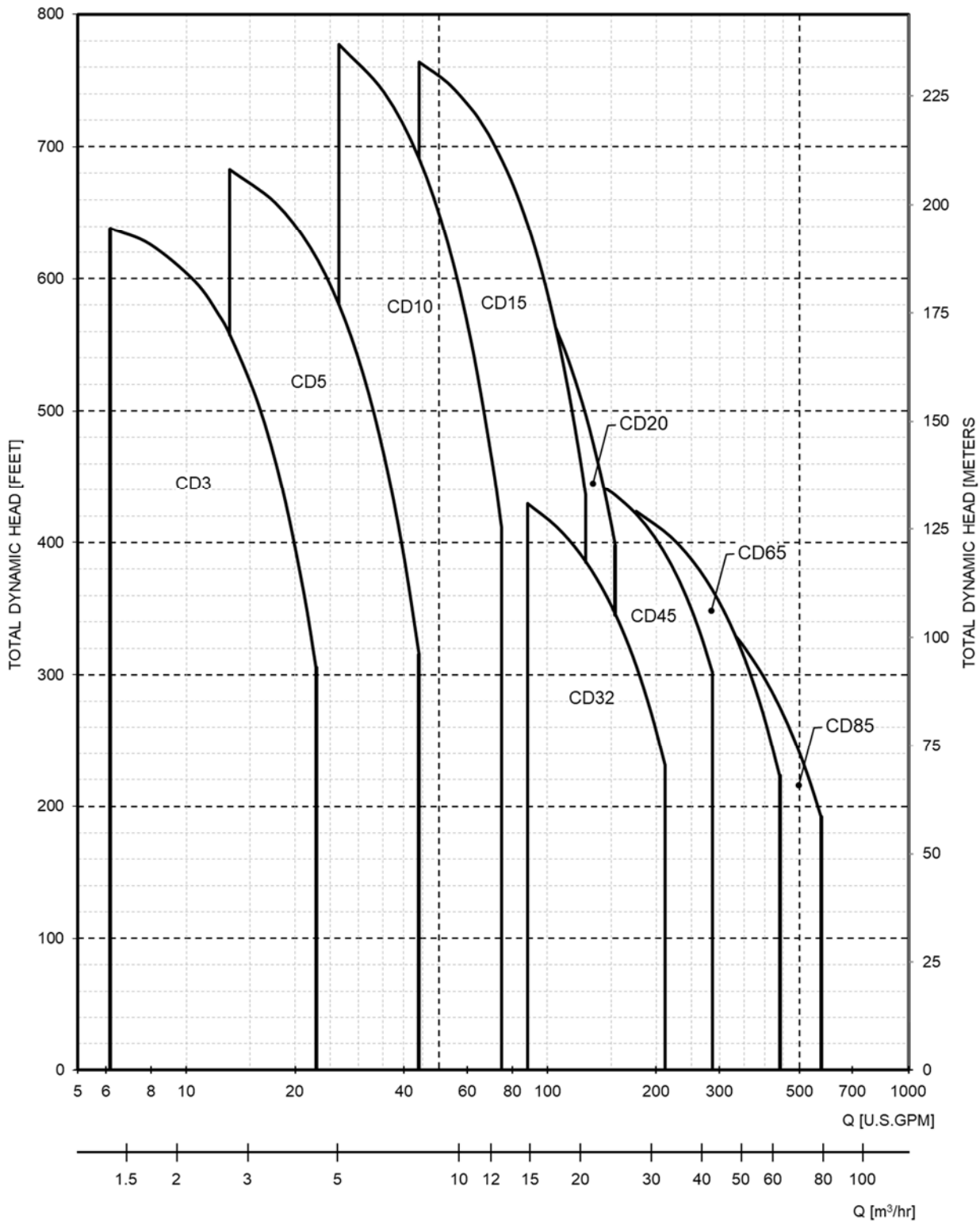

Dimensions and Weights CD3

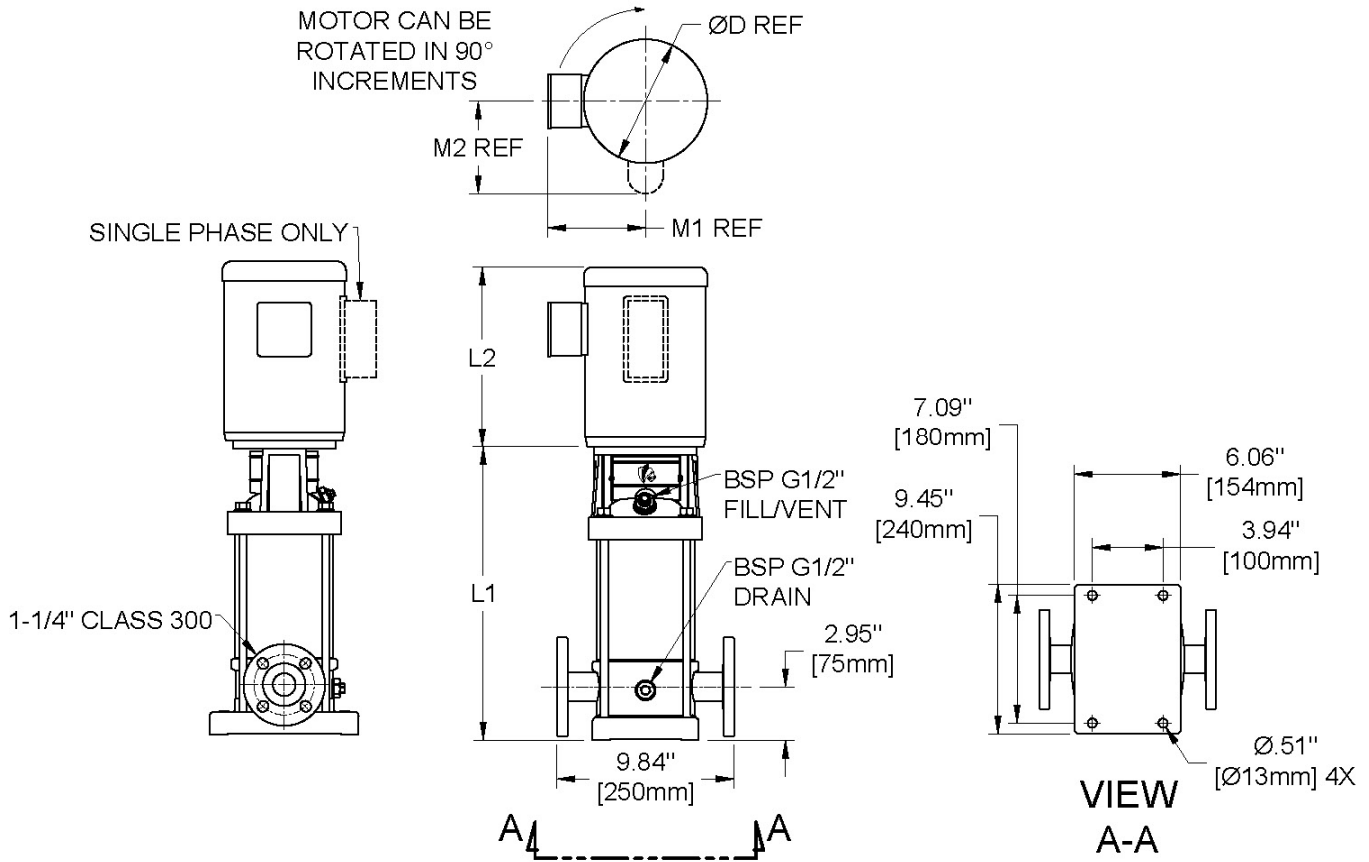

MODEL	HP	FRAME	DIMENSIONS (in)								WEIGHT (lbs)		
			L1	L2	TEFC 1 ϕ			TEFC 3 ϕ		TEFC 1 ϕ	TEFC 3 ϕ	WET-END ONLY	
					D	M1	M2	L2	D				
CD3-3	0.75	56C	11	11.29	6.2	5.2	5.4	11.29	6.19	62	54	33	
CD3-4	0.75	56C	12	11.29	6.2	5.2	5.4	11.29	6.19	62	54	33	
CD3-4	1	56C	12	13.41	7.2	5.8	5.6	13.42	7.01	69	65	33	
CD3-5	1	56C	13	13.41	7.2	5.8	5.6	13.42	7.01	71	67	35	
CD3-7	1.5	56C	15	13.41	7.2	5.8	5.6	13.42	7.01	77	72	37	
CD3-9	2	56C	17	13.41	7.2	5.8	5.6	13.42	7.01	115	85	42	
CD3-10	2	56C	17	13.41	7.2	5.8	5.6	13.42	7.01	115	85	42	
CD3-12	3	182TC	19	15.18	8.6	6.9	6.2	13.41	7.19	117	94	44	
CD3-14	3	182TC	21	15.18	8.6	6.9	6.2	13.41	7.19	122	99	49	
CD3-16	3	182TC	23	15.18	8.6	6.9	6.2	13.41	7.19	124	101	51	
CD3-16	5	184TC	23					15.43	8.5		126	51	
CD3-18	5	184TC	24					15.43	8.5		128	53	

Performance Curves CD3

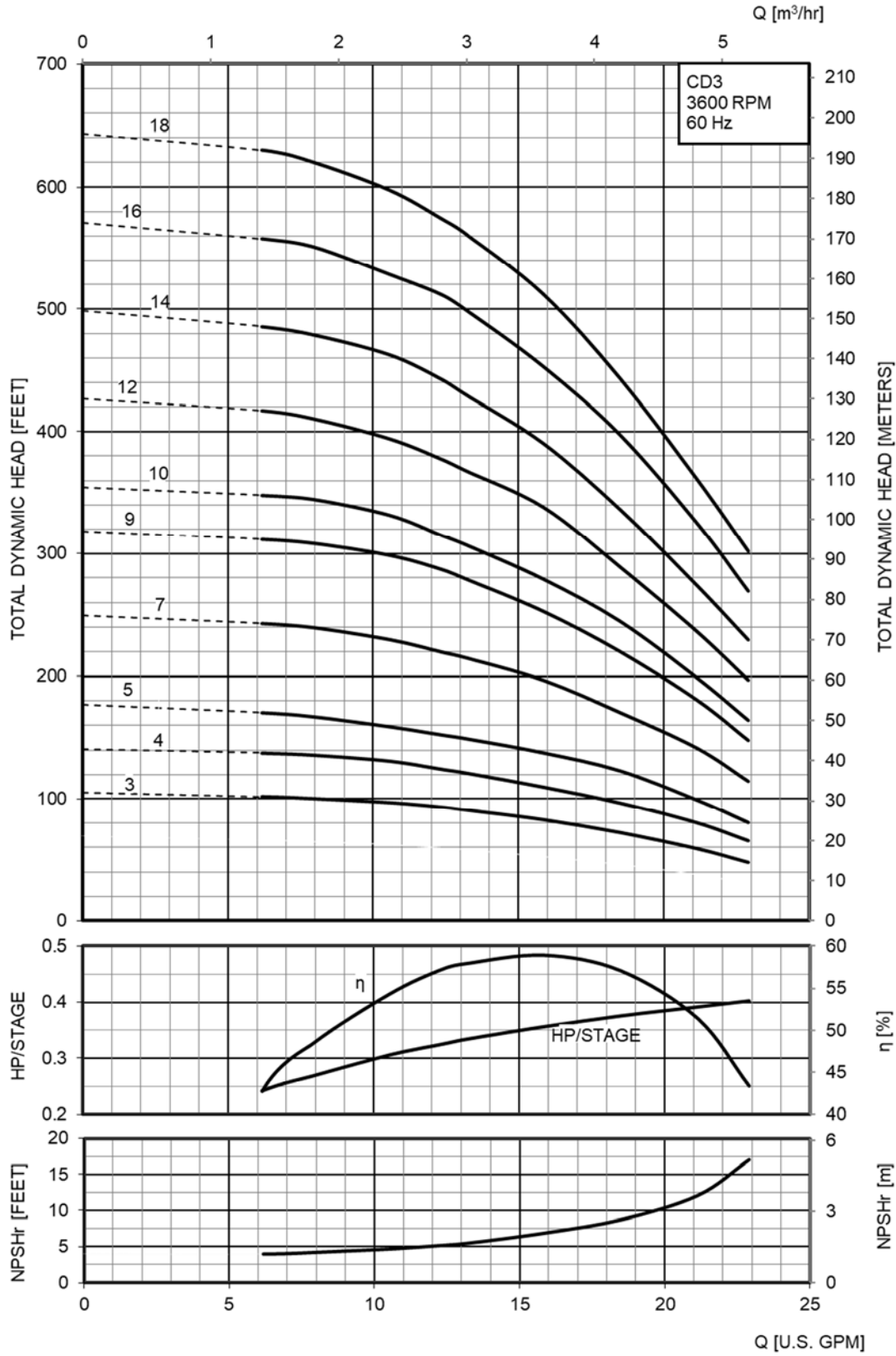

Dimensions and Weights CD5

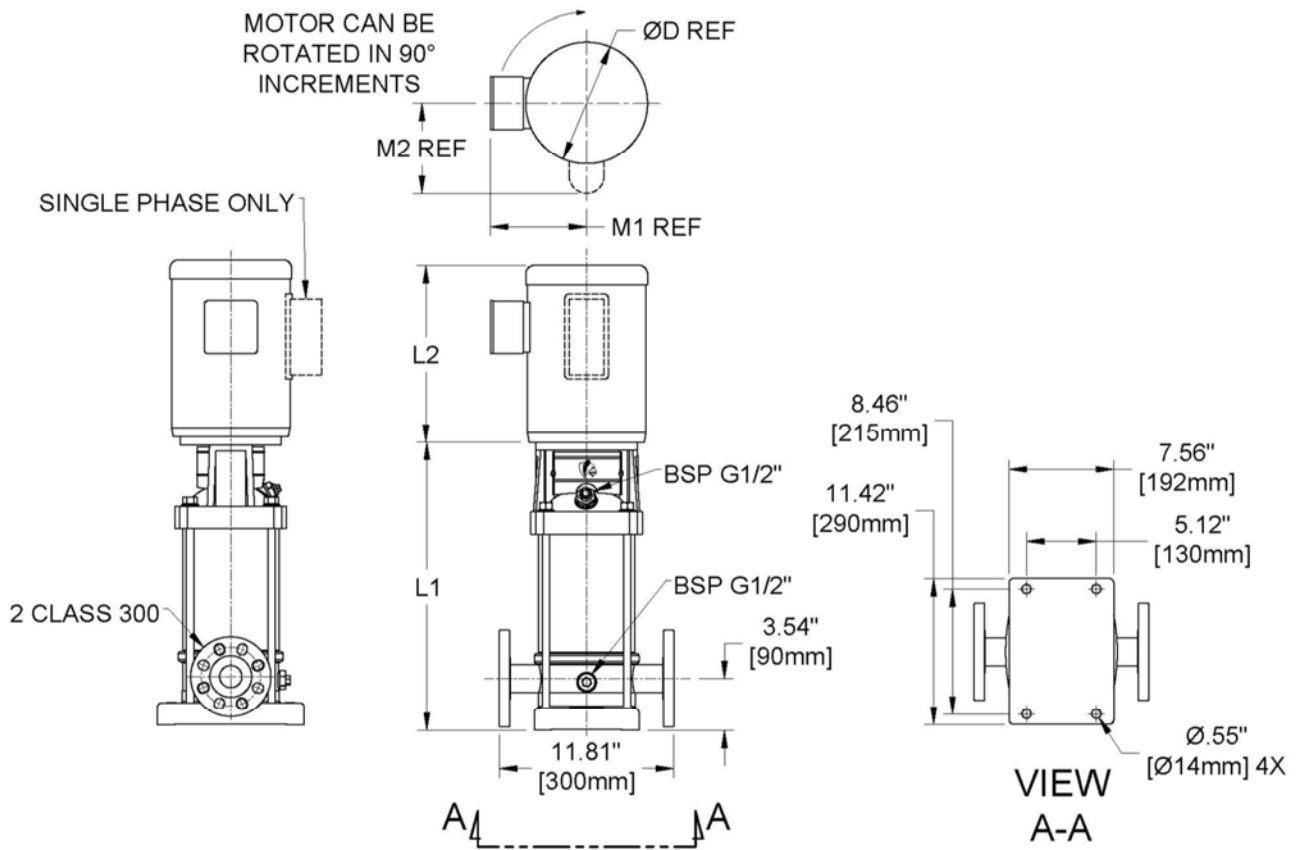

MODEL	HP	FRAME	DIMENSIONS (in)								WEIGHT (lbs)		
			L1	TEFC 1φ				TEFC 3φ		TEFC 1φ	TEFC 3φ	WET-END ONLY	
				L2	D	M1	M2	L2	D				
CD5-3	1	56C	12	13.41	7.2	5.8	5.6	13.42	7.01	73	69	37	
CD5-4	1.5	56C	13	13.41	7.2	5.8	5.6	13.42	7.01	75	70	35	
CD5-6	2	56C	16	13.41	7.2	5.8	5.6	13.42	7.01	113	83	40	
CD5-7	3	182TC	17	15.18	8.6	6.9	6.2	13.41	7.19	115	92	42	
CD5-9	3	182TC	19	15.18	8.6	6.9	6.2	13.41	7.19	117	94	44	
CD5-10	3	182TC	21	15.18	8.6	6.9	6.2	13.41	7.19	122	99	49	
CD5-10	5	184TC	21					15.43	8.5		124	49	
CD5-12	5	184TC	23					15.43	8.5		126	51	
CD5-13	5	184TC	24					15.43	8.5		128	53	
CD5-15	5	184TC	26					15.43	8.5		130	55	
CD5-16	5	184TC	27					15.43	8.5		135	60	
CD5-18	7.5	213TC	32					15.18	8.6		156	60	
CD5-20	7.5	213TC	34					15.18	8.6		158	62	

Performance Curves CD5

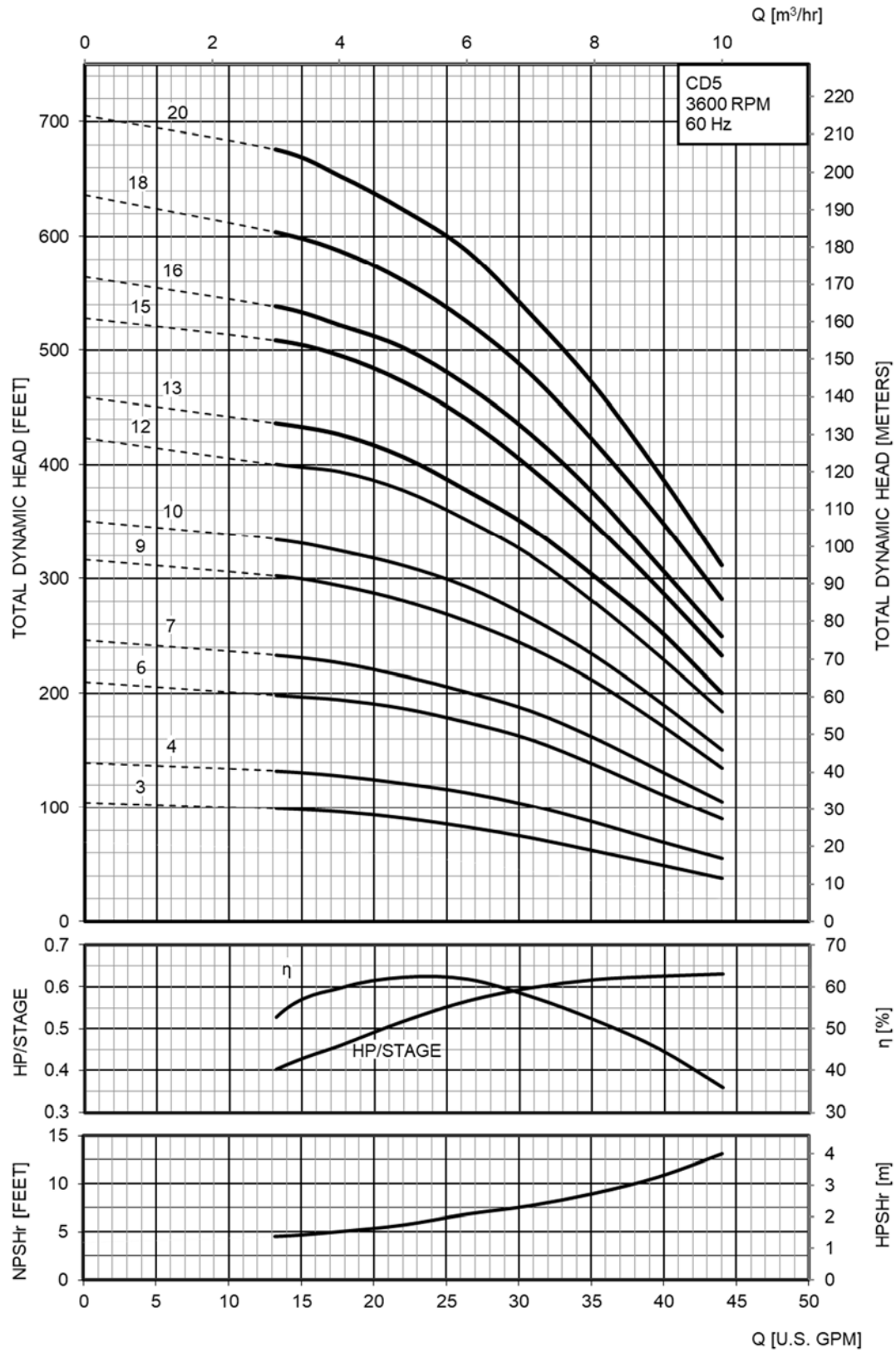

Dimensions and Weights CD10

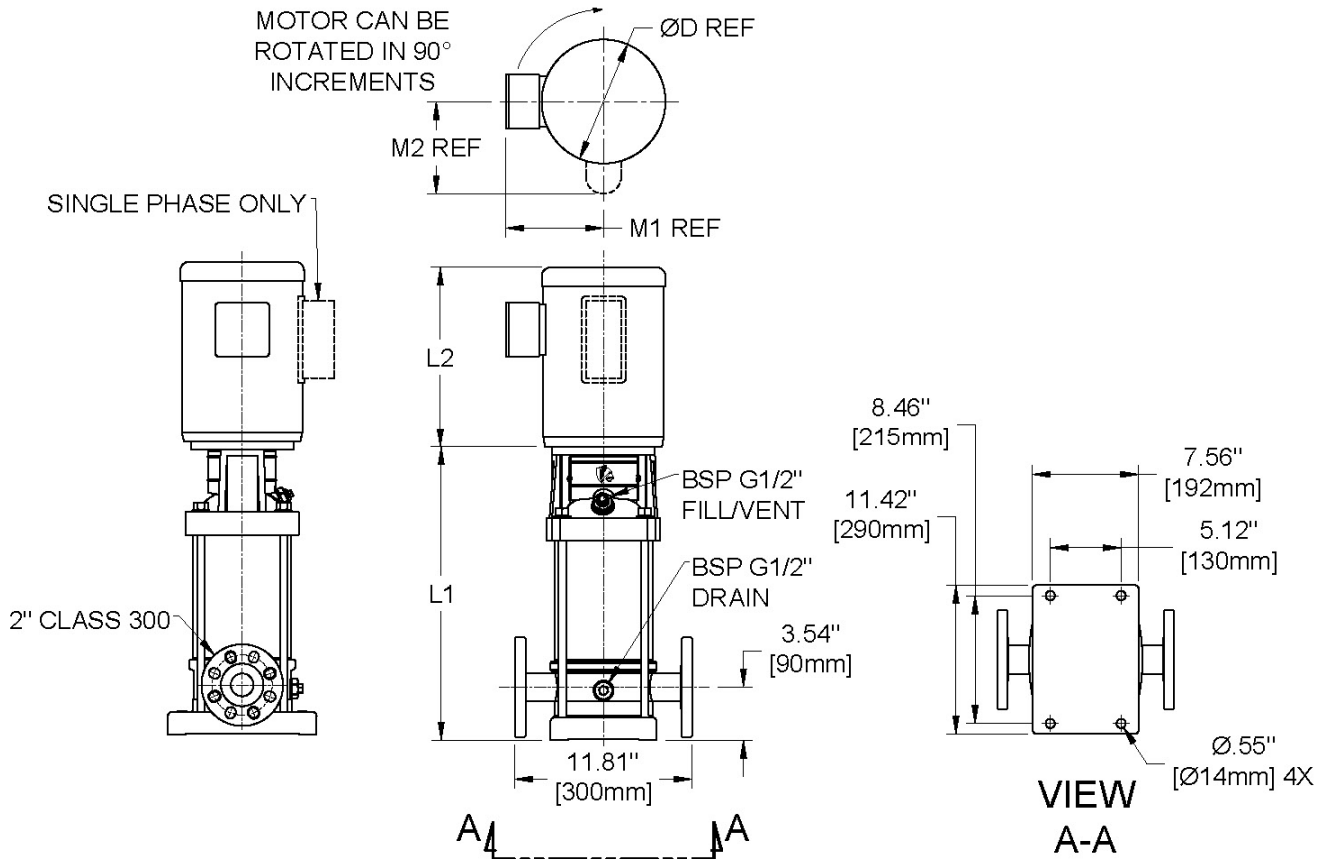

MODEL	HP	FRAME	DIMENSIONS (in)								WEIGHT (lbs)		
			L1	TEFC 1 ϕ				TEFC 3 ϕ		TEFC 1 ϕ	TEFC 3 ϕ	WET-END ONLY	
				L2	D	M1	M2	L2	D				
CD10-2	2	56C	14.4	13.4	7.2	5.8	5.6	13.42	7.01	128	98	55	
CD10-3	3	182TC	16	15.2	8.6	6.9	6.2	13.41	7.19	133	110	60	
CD10-4	5	184TC	17					15.43	8.5		137	62	
CD10-5	5	184TC	18					15.43	8.5		137	62	
CD10-6	5	184TC	20					15.43	8.5		143	68	
CD10-7	7.5	213TC	24					15.18	8.6		164	68	
CD10-8	7.5	213TC	25					15.18	8.6		215	119	
CD10-9	7.5	213TC	26					15.18	8.6		175	79	
CD10-10	10	215TC	27					17.89	10.28		204	79	
CD10-11	10	215TC	29					17.89	10.28		255	130	
CD10-12	10	215TC	30					17.89	10.28		257	132	
CD10-13	15	215TC	32					16.32	11.5		379	154	
CD10-14	15	215TC	33					16.32	11.5		384	159	
CD10-15	15	215TC	34					16.32	11.5		384	159	

Performance Curves CD10

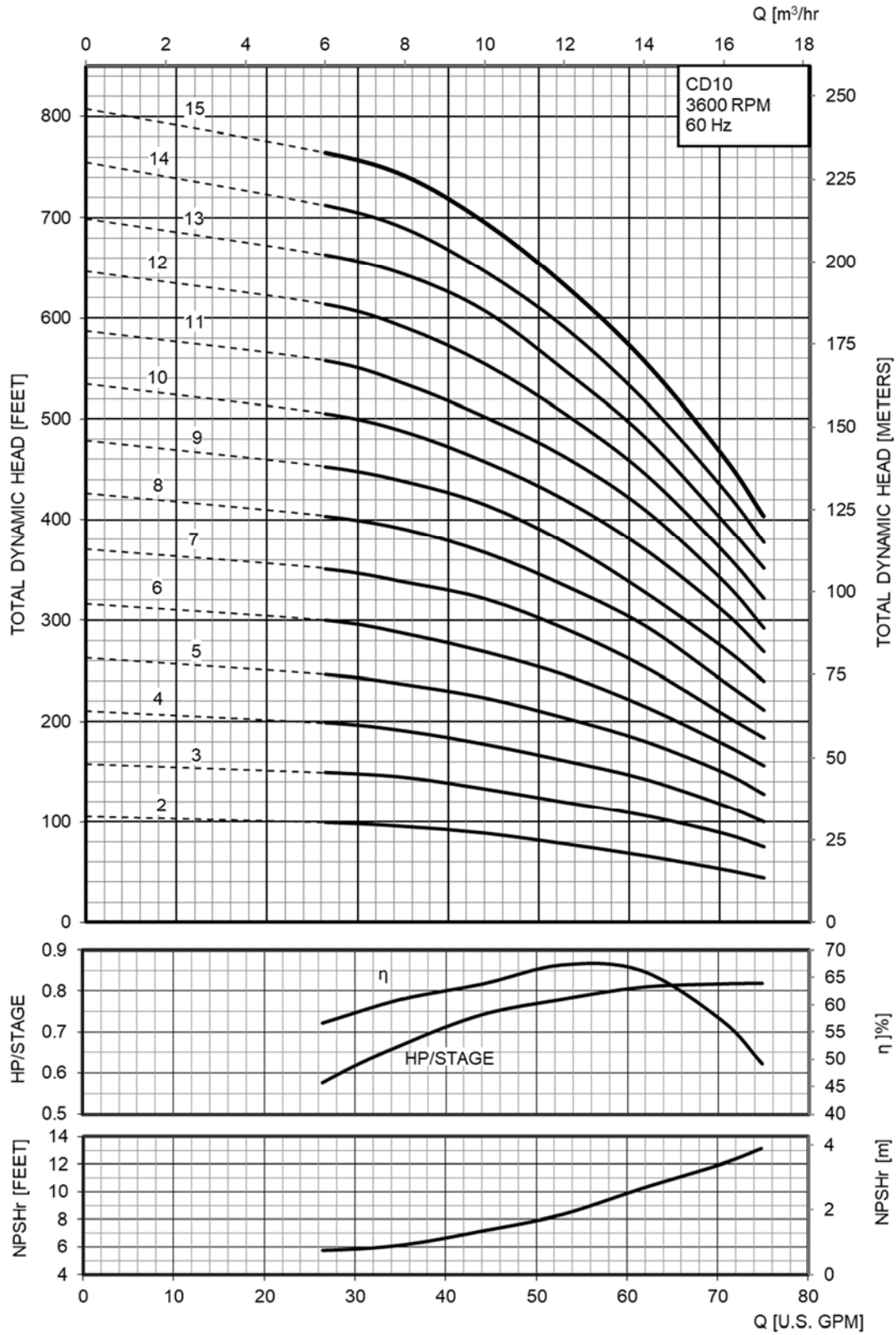

Dimensions and Weights CD15

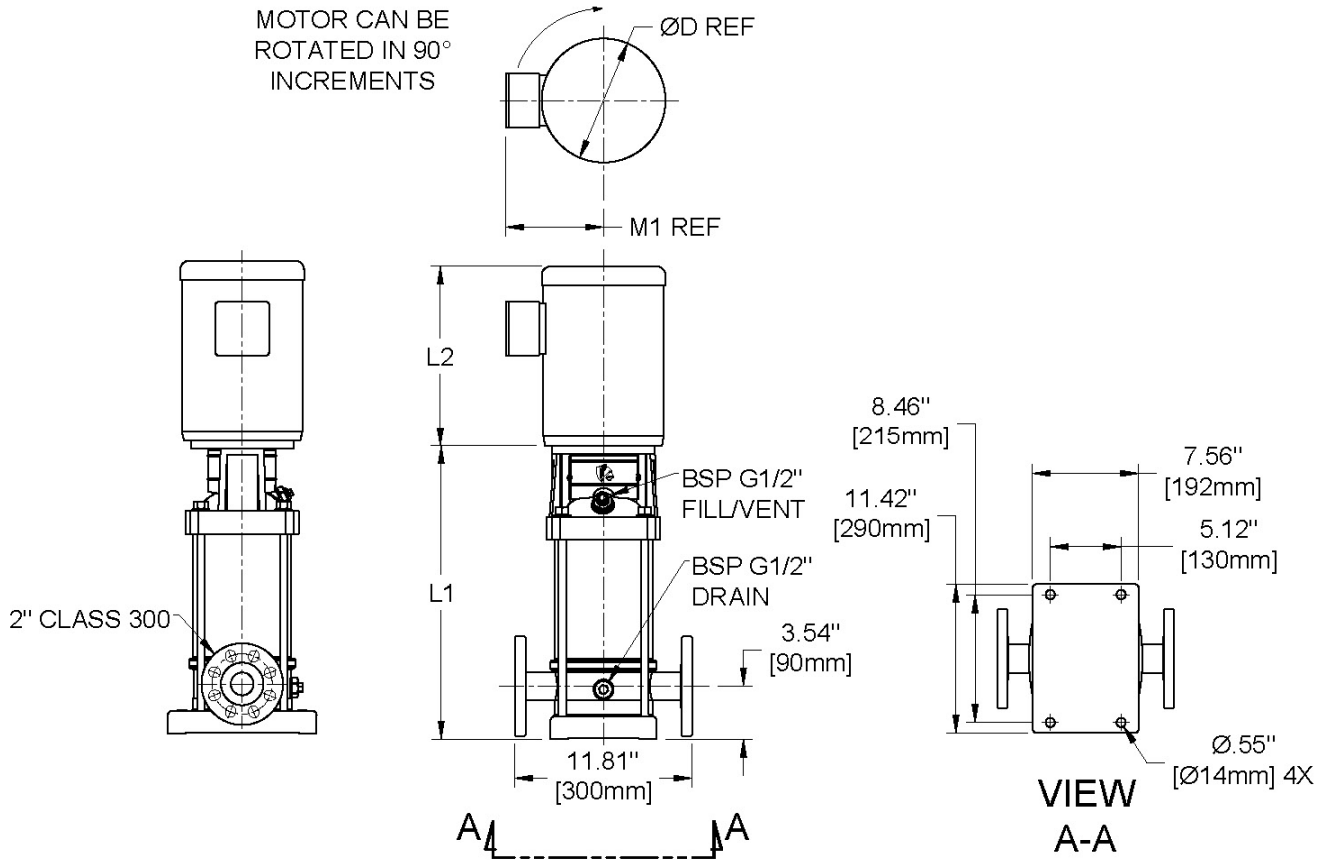

MODEL	HP	FRAME	DIMENSIONS (in)				WEIGHT (lbs)	
			L1	L2	D	M1	PUMP & MOTOR	WET-END ONLY
CD15-2	5	184TC	16	15.43	8.5	6.87	132	57
CD15-3	5	184TC	18	15.43	8.5	6.87	137	62
CD15-3	7.5	213TC	18	15.18	8.6	5.91	158	62
CD15-4	7.5	213TC	23	15.18	8.6	5.91	158	62
CD15-5	10	215TC	24	17.89	10.28	8.05	202	77
CD15-6	10	215TC	27	17.89	10.28	8.05	207	82
CD15-6	15	215TC	27	17.89	11.5	9.22	307	82
CD15-8	15	215TC	31	17.89	11.5	9.22	355	130
CD15-9	15	215TC	33	17.89	11.5	9.22	357	132
CD15-9	20	256TC	33	19.8	12.94	10.04	361	132
CD15-11	20	256TC	36	19.8	12.94	10.04	366	137
CD15-12	20	256TC	38	19.8	12.94	10.04	366	137
CD15-12	25	284TSC	38	19.8	12.94	11.52	460	137

Performance Curves CD15

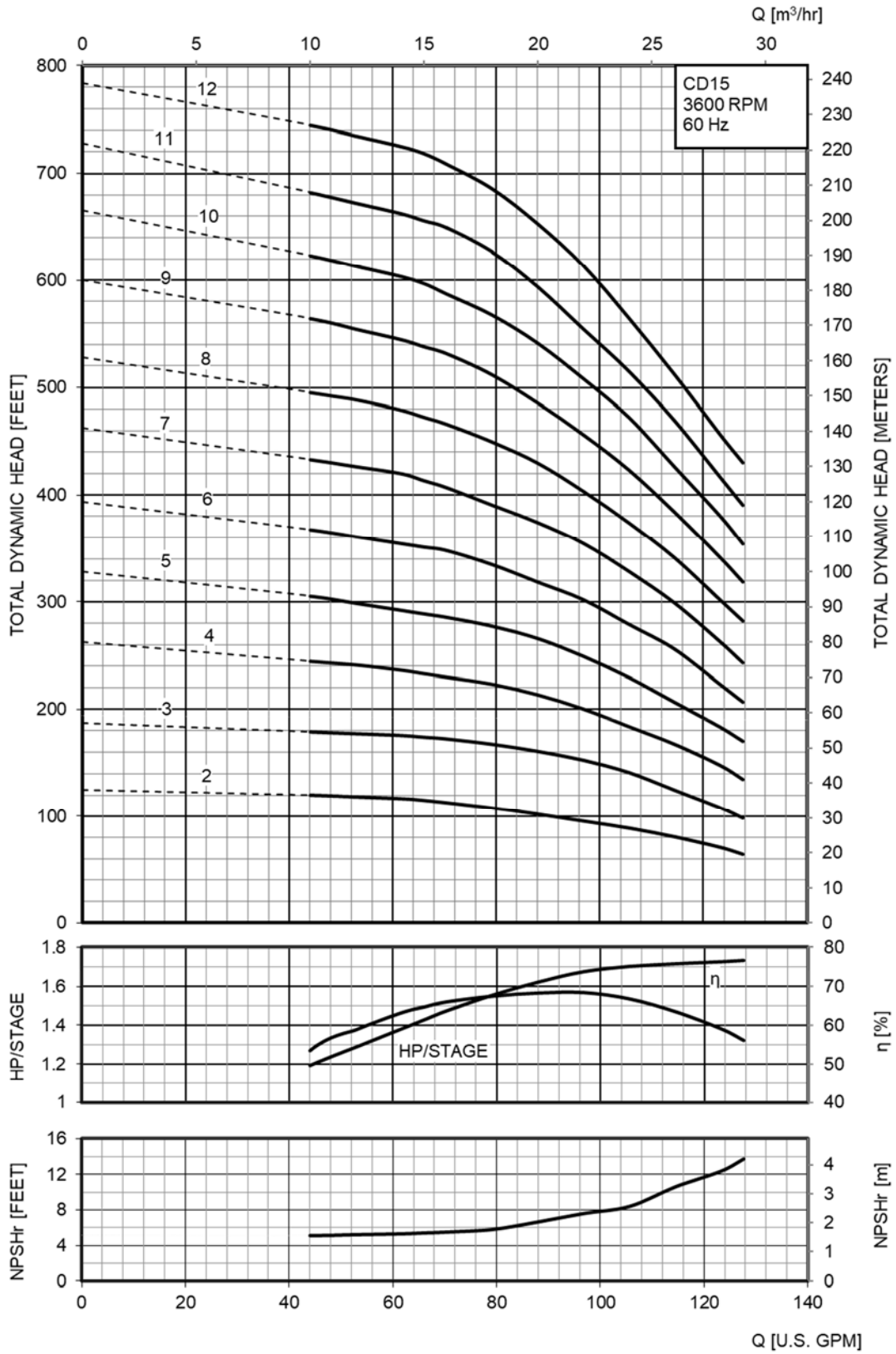

Dimensions and Weights CD20

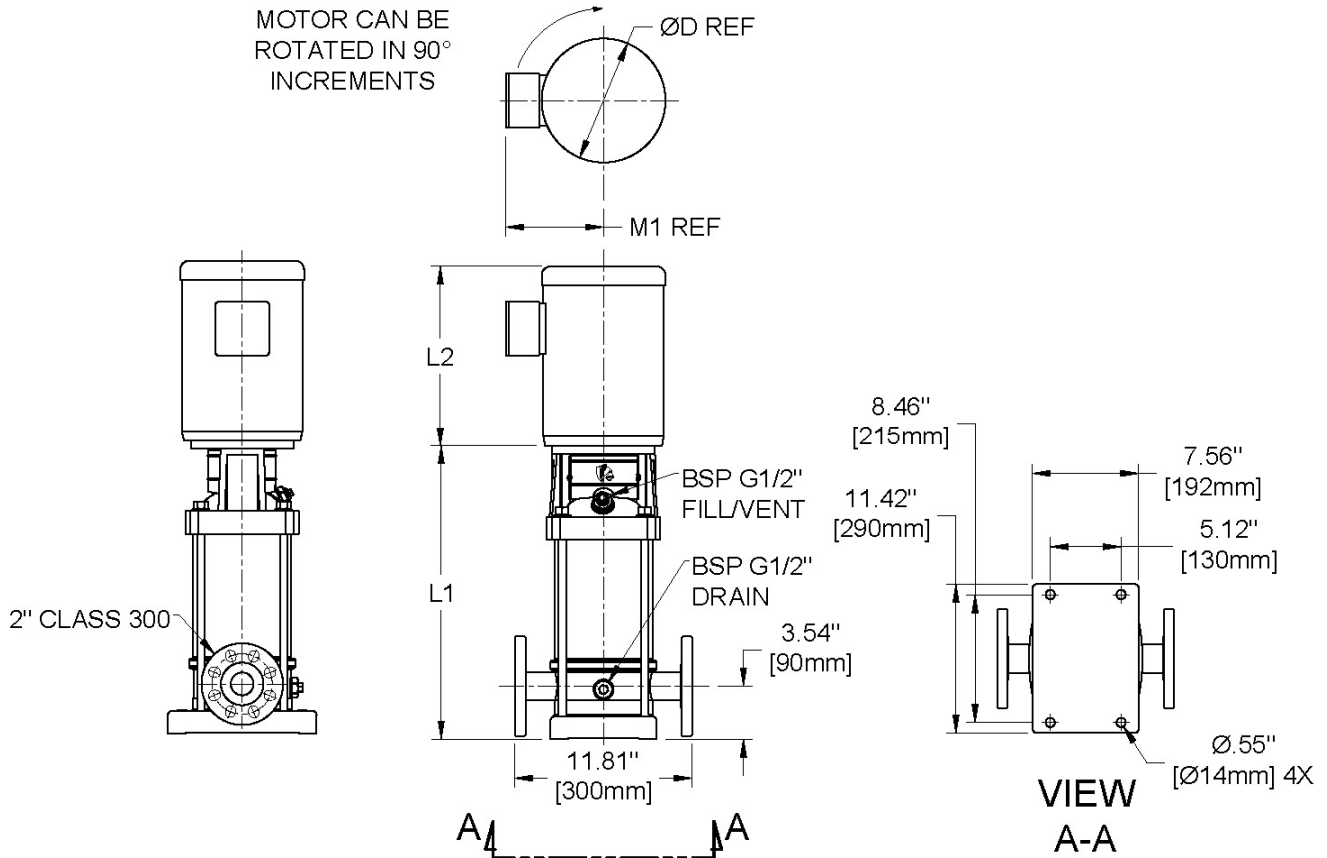

PN	HP	FRAME	DIMENSIONS (in)				WEIGHT (lbs)	
			L1	L2	D	M1	PUMP & MOTOR	WET-END ONLY
CD20-2	5	184TC	16	15.43	8.5	6.87	132	57
CD20-3	7.5	213TC	21	15.18	8.6	5.91	158	62
CD20-4	10	215TC	23	17.89	10.28	8.05	198	73
CD20-5	15	215TC	26	16.32	11.5	9.22	302	77
CD20-6	15	215TC	27	16.32	11.5	9.22	346	121
CD20-7	15	215TC	29	16.32	11.5	9.22	353	128
CD20-7	20	256TC	29	19.8	12.94	10.04	357	128
CD20-8	20	256TC	31	19.8	12.94	10.04	359	130
CD20-9	20	256TC	33	19.8	12.94	10.04	366	137
CD20-9	25	284TSC	33	19.15	12.94	11.52	460	137
CD20-10	25	284TSC	34	19.15	12.94	11.52	464	141

Performance Curves CD20

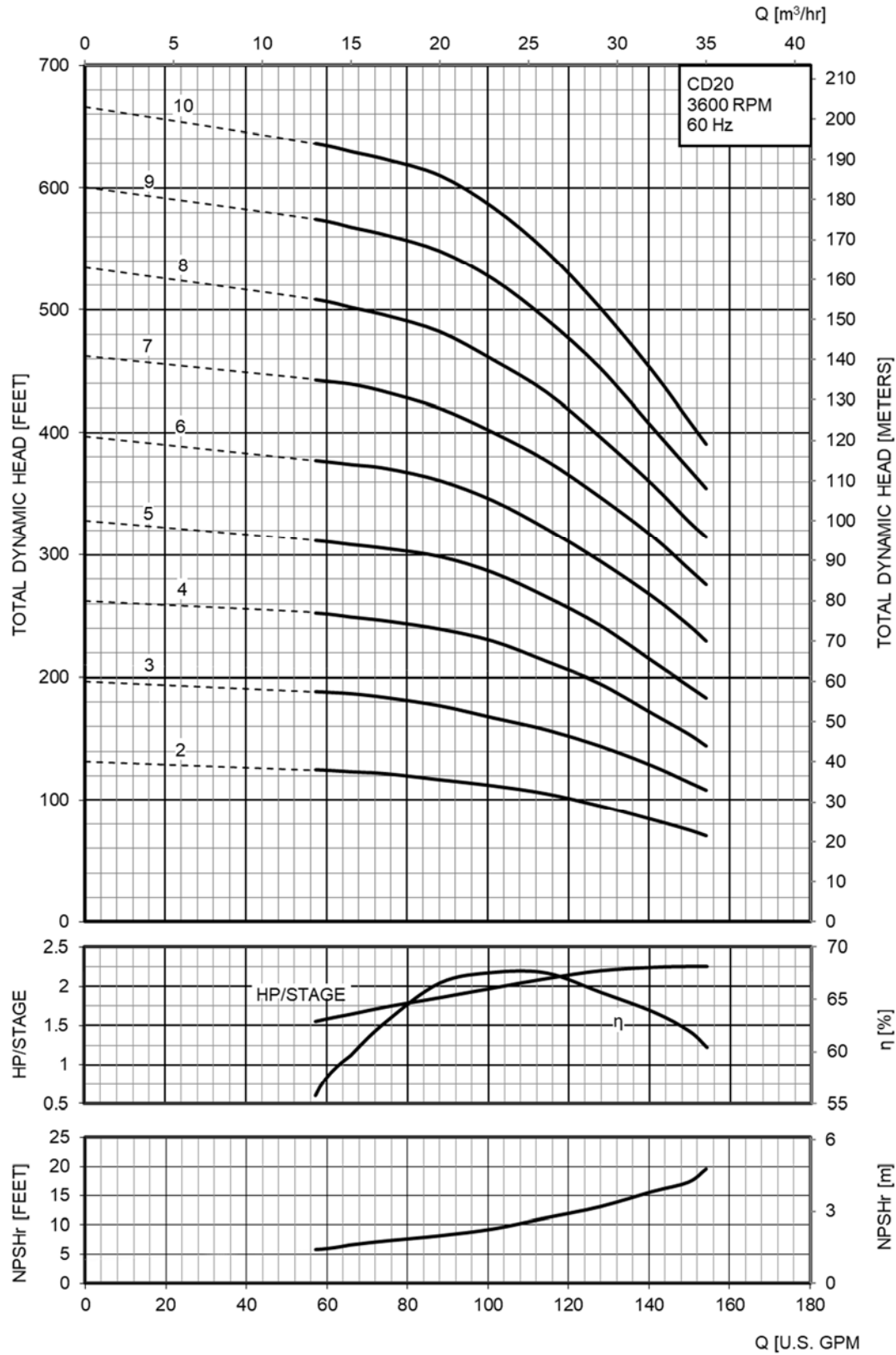

Dimensions and Weights CD32

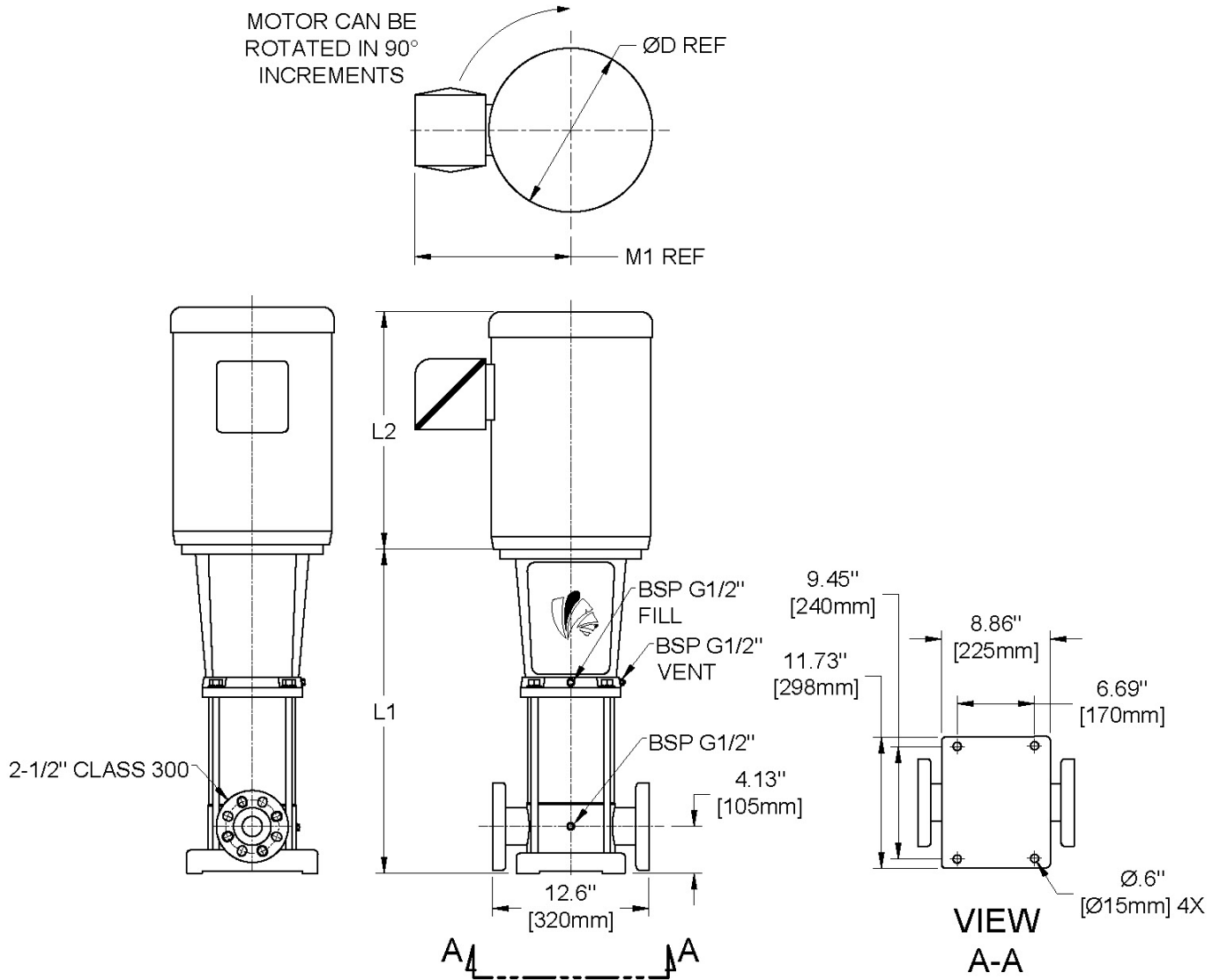

PN	HP	FRAME	DIMENSIONS (in)				WEIGHT (lbs)	
			L1	L2	D	M1	PUMP & MOTOR	WET-END ONLY
CD32-2-2	7.5	213TC	27	15.18	8.6	5.91	248	152
CD32-2	7.5	213TC	27	15.18	8.6	5.91	235	139
CD32-2	10	215TC	27	17.89	10.28	8.05	264	139
CD32-3-2	10	215TC	30	17.89	10.28	8.05	306	181
CD32-3	10	215TC	34	17.89	10.28	8.05	306	181
CD32-3	15	215TC	34	16.32	11.5	9.22	406	181
CD32-4-2	15	215TC	36	16.32	11.5	9.22	415	190
CD32-4	15	215TC	36	16.32	11.5	9.22	415	190
CD32-4	20	256TC	36	19.8	12.94	10.04	419	190
CD32-5-2	20	256TC	39	19.8	12.94	10.04	432	203
CD32-5	20	256TC	39	19.8	12.94	10.04	432	203

Performance Curves CD32

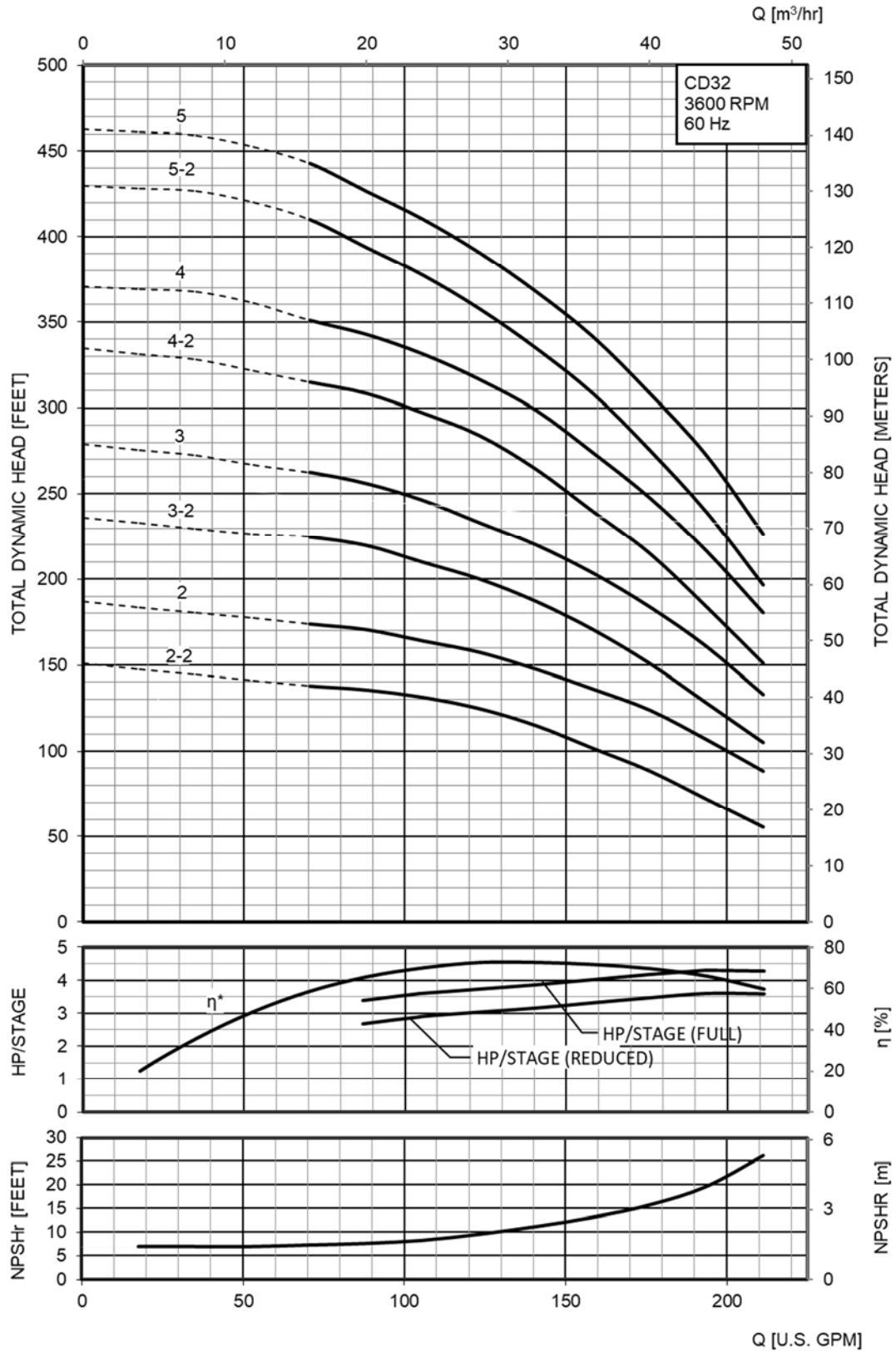

Dimensions and Weights CD42

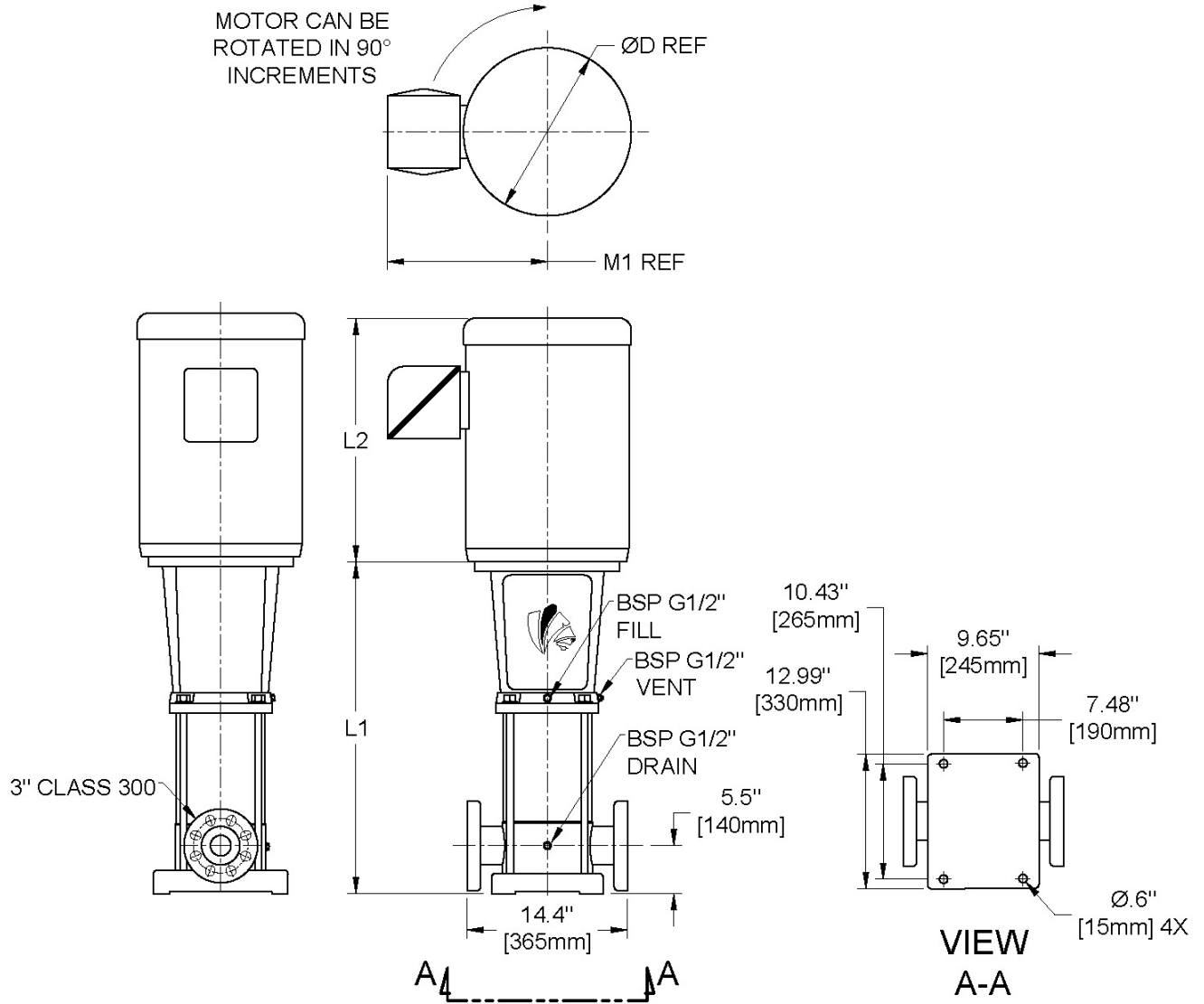

MODEL	HP	FRAME	DIMENSIONS (in)				WEIGHT (lbs)	
			L1	L2	D	M1	PUMP & MOTOR	WET-END ONLY
CD42-1	7.5	213TC	28	15.18	8.6	5.91	257	161
CD42-2-2	15	215TC	35	16.32	11.5	9.22	454	229
CD42-2	15	215TC	35	16.32	11.5	9.22	423	198
CD42-3-2	20	256TC	38	19.8	12.94	10.04	447	218
CD42-3	25	284TSC	38	19.15	12.94	11.52	541	218
CD42-4-2	25	284TSC	41	19.15	12.94	11.52	552	229
CD42-4-2	30	286TSC	41	19.15	12.94	11.52	622	229
CD42-4	30	286TSC	41	19.15	12.94	11.52	633	240
CD42-4	40	324TSC	41	25.14	14.78	13.74	710	240

Performance Curves CD42

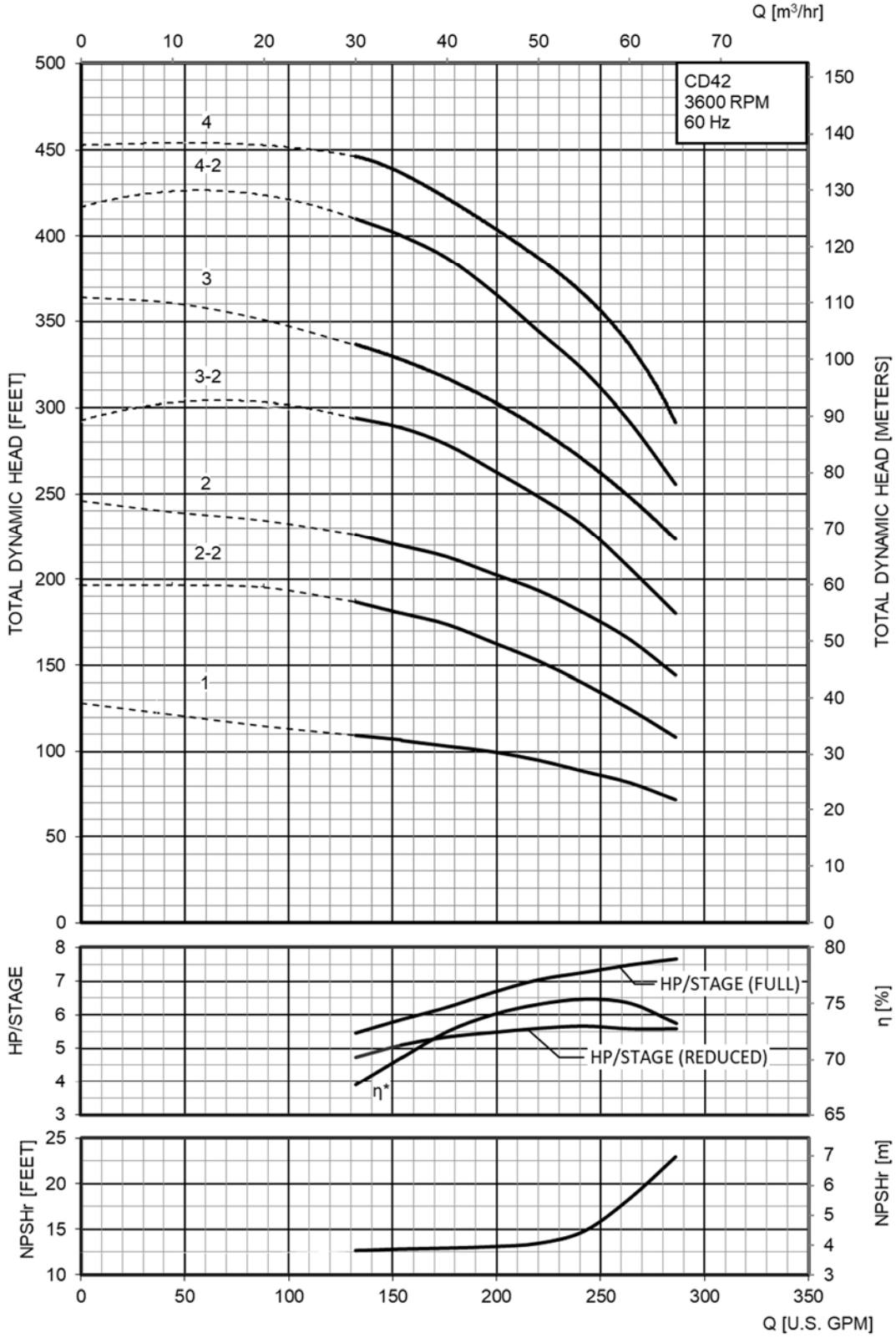

Dimensions and Weights CD65

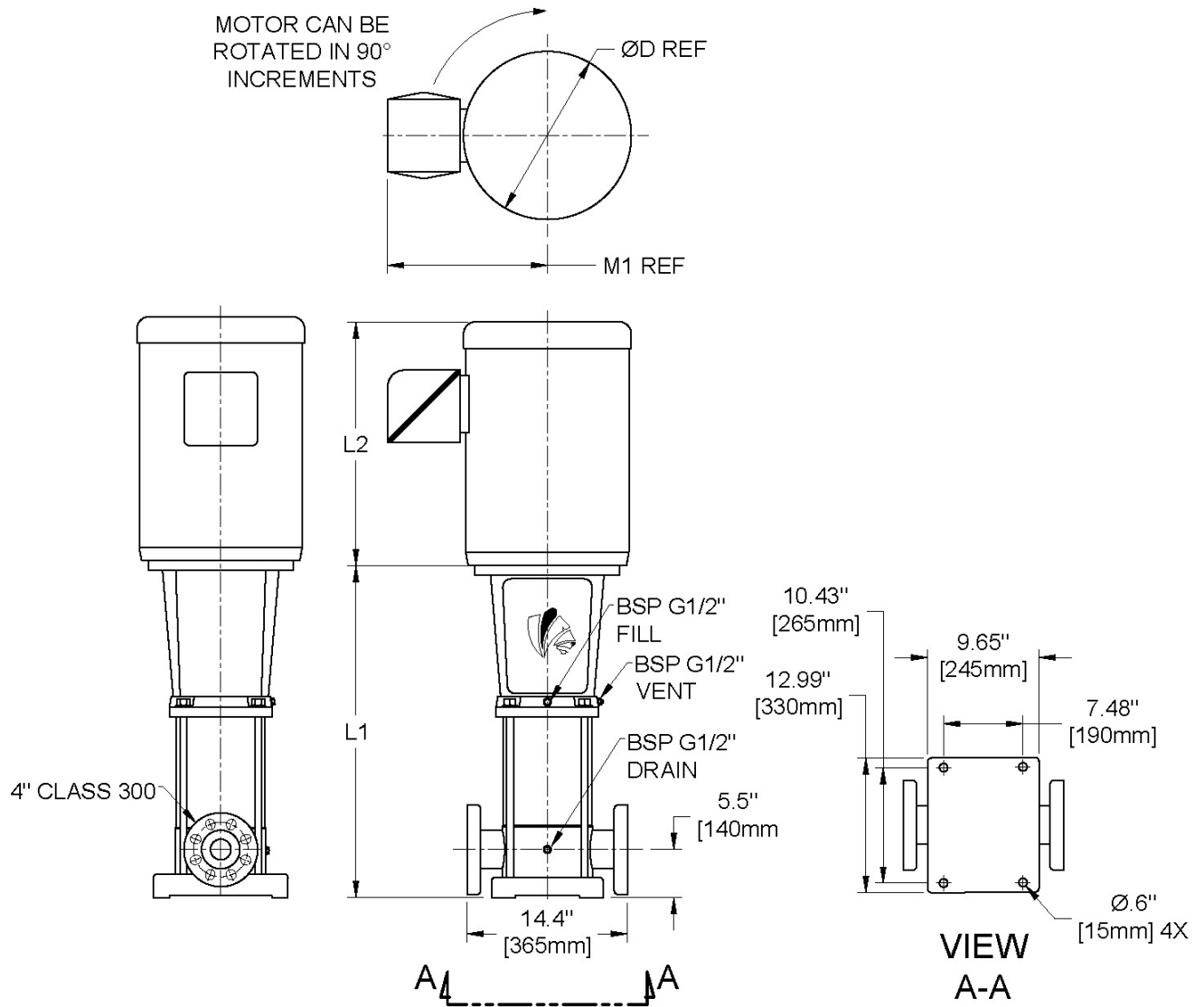

MODEL	HP	FRAME	DIMENSIONS (in)				WEIGHT (lbs)	
			L1	L2	D	M1	PUMP & MOTOR	WET-END ONLY
CD65-1	15	215TC	32	16.32	11.5	9.22	423	198
CD65-2-2	15	215TC	35	16.32	11.5	9.22	437	212
CD65-2	25	284TSC	35	19.15	12.94	11.52	541	218
CD65-3-2	25	284TSC	38	19.15	12.94	11.52	554	231
CD65-3	40	324TSC	38	25.14	14.78	13.74	713	243
CD65-4-2	40	324TSC	42	25.14	14.78	13.74	726	256

Performance Curves CD65

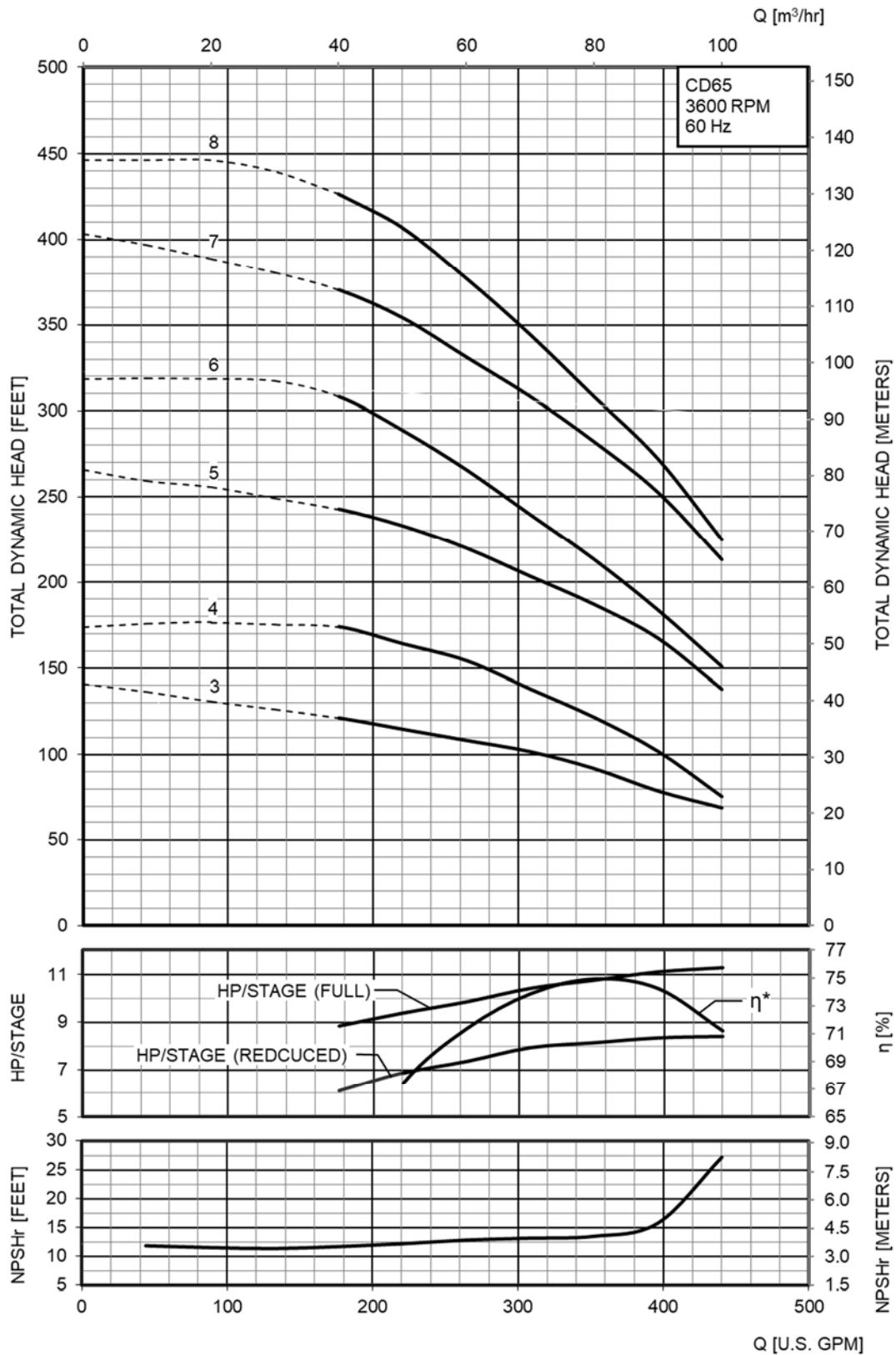

*

Dimensions and Weights CD85

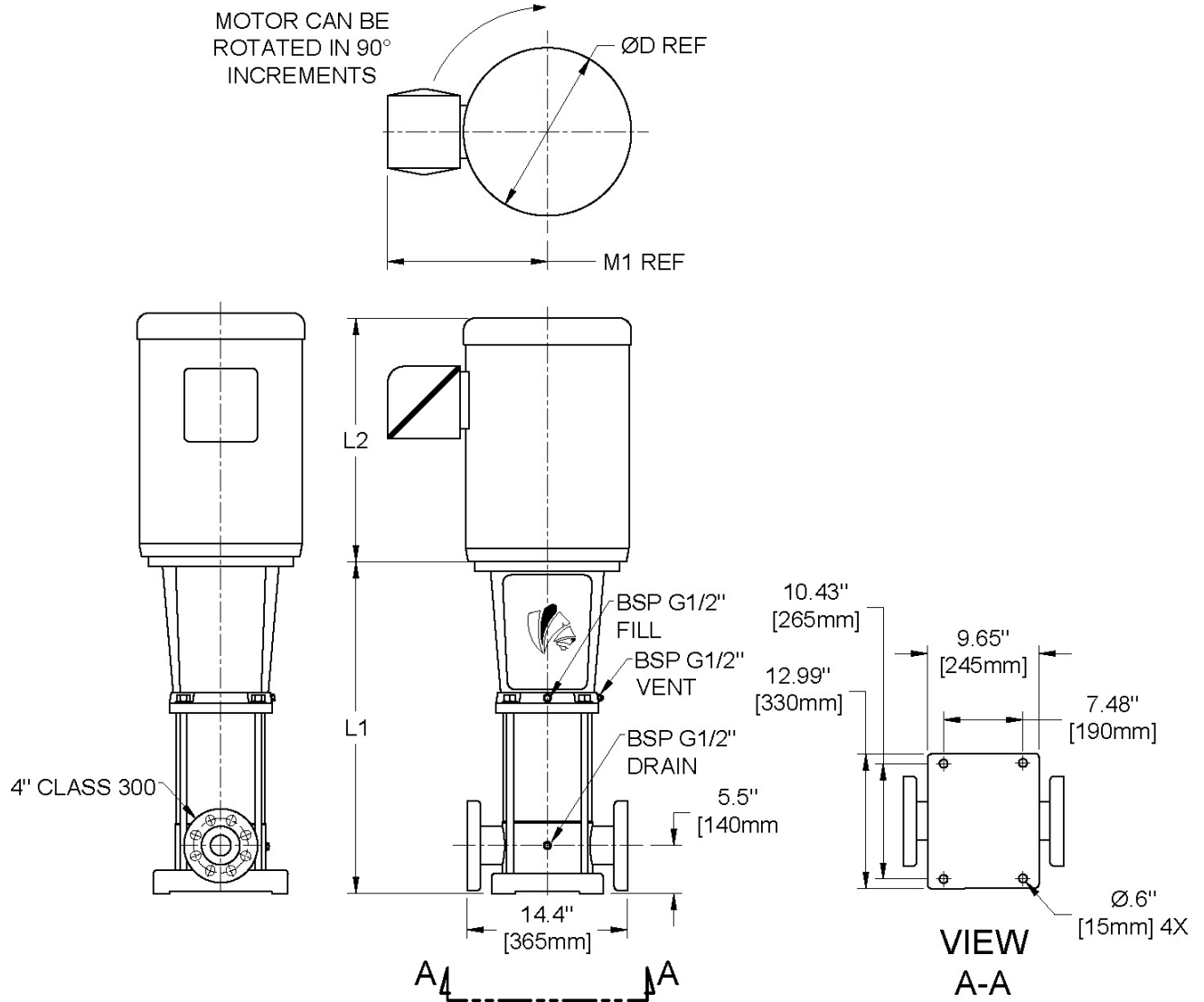

PN	HP	FRAME	DIMENSIONS (in)				WEIGHT (lbs)	
			L1	L2	D	M1	PUMP & MOTOR	WET-END ONLY
CD85-1	15	215TC	28	16.32	11.5	9.22	428	203
CD85-2-2	20	256TC	36	19.8	12.94	10.04	460	231
CD85-2-2	25	284TSC	36	19.15	12.94	11.52	554	231
CD85-2-1	25	284TSC	36	19.15	12.94	11.52	554	231
CD85-2-1	30	286TSC	36	19.15	12.94	11.52	624	231
CD85-2	30	286TSC	36	19.15	12.94	11.52	624	231
CD85-2	40	324TSC	36	25.14	14.78	13.74	701	231
CD85-3-2	40	324TSC	40	25.14	14.78	13.74	717	247
CD85-3-1	40	324TSC	40	25.14	14.78	13.74	717	247
CD85-3-1	50	326TSC	40	28.03	16.88	14.63	825	247
CD85-3	50	326TSC	40	28.03	16.88	14.63	847	269

Performance Curves CD85

